

Data sheet

Temperature transmitter

MBT 9110

MBT 9110 transmitter with box enclosure

Standard transmitter: D

Galvanic isolated transmitter: E

MBT 9110 transmitter for B-head

High cap for integration with B-head temperature sensor.

Standard transmitter: A

Galvanic isolated transmitter: B

MBT 9110 transmitter as terminal block

Standard transmitter: G

Galvanic isolated transmitter: H

The MBT 9110 temperature transmitter can be used for converting the Pt 100 / Pt 1000 ohm signal or the thermo couple mV signal to a 4 – 20 mA signal.

The MBT 9110 is a very durable and reliable temperature transmitter with all major marine approvals and can be used together with all our sensors based on Pt or Thermocouple technology.

MBT 9110 transmitters in the standard program are delivered in an enclosure, but are also used as an integrated part of certain temperature sensors.

The transmitter is available as standard or galvanic isolated with or without EEx approval.

Features

- 2-wire universal transmitter for industrial and maritime applications
- Pt 100, Pt 1000 or thermocouple input
- 4 – 20 mA standard output - with or without galvanic isolation
- For mounting in DIN B connection head, heightened lid or in a separate enclosure
- Advanced sensor fault indication
- Temperature linearized

Approvals

Lloyds Register of Shipping, LR
 Germanischer Lloyd, GL
 Det Norske Veritas, DNV

Nippon Kaiji Kyokai, NKK
 China Classification Society, CCS
 Bureau Veritas, BV

Technical data
Performance

Primary accuracy	Pt 100 <math>< \pm 0.3 \text{ }^\circ\text{C}</math> Thermocouple type E, J, K, L, N, T, U <math>< \pm 1.0 \text{ }^\circ\text{C}</math> Thermocouple type B, R, S <math>< \pm 2.0 \text{ }^\circ\text{C}</math>
Linearity error	<math>< 0.1\% \text{ FS}</math>
Temp. coefficient	<math>< \pm 0.01\% \text{ FS} / \text{ }^\circ\text{K}_{\text{amb}}</math>
Response time	Programmable 1 – 60 sec. 1 sec. standard
Cold solder point compensation (CJC)	<math>< \pm 1.0 \text{ }^\circ\text{C}</math>
Warm-up time	5 min.
Update time	440 ms
Effect of sensor cable resistance (3/4 wires)	<math>< 0.002 \text{ } \Omega / \Omega</math>

 K_{amb} = Ambient temperature change

Electrical specifications

Supply voltage	8 – 35 V d.c.
EEx Galvanic supply voltage	7.2 – 30 V d.c.
Effect of supply voltage variation	<math>< 0.005\% \text{ FS} / \text{ V d.c.}</math>
Output	4 – 20 mA current loop
Sensor fault indication	Namur NE43 upscale 23 mA
Input	Standard Pt 100 (EN 60751) 2, 3 - wire -200 – 800 °C Pt 1000 (EN 60751) 2, 3 - wire
	Galvanic isolation Pt 100 (EN 60751) 2, 3, 4 - wire -200 – 800 °C Pt 1000 (EN 60751) 2, 3 - wire Thermocouple (EN 60584)
Signal/noise ratio	Min. 60 dB
Max. lead cross-section	1 × 1.5 mm ²
Max. cable resistance	5 Ω / core

Environmental conditions for Box enclosure

Insulation voltage	1500 V a.c.
EMC	EN 61326-1
Vibration/shock	IEC 60068-2-6 / IEC 60068-2-84
Vibration	4 g / 2 – 100 Hz
Humidity	0 – 98% RH, according to IEC 60068-1, IEC 60068-2-2
Ambient temperature	-40 – 70 °C
In separate enclosure	IP54 according to IEC 60529

Mechanical characteristics

Max. offset	50% of max. input value (Pt 100: 400 °C) (Thermocouple, type R: 650 °C)
Net weight	In heightened lid for B-head: 0.080 kg In Box enclosure: 0.360 kg

Ordering standard

Type MBT 9110		Transmitter	
Application	Marine	0	0 0
Size	Standard	0	1 1
Sensor element	Pt 100 resistance element	0	2 2
	Thermocouple, Type K, NiCr-Ni	5	3 3
	Pt 1000 resistance element	D	4 4
	Other	9	5 5
Connections	2 wires	A	6 6
	3 wires ¹⁾	B	7 7
	4 wires	C	8 8
			9 9
			0
			1
			4
			9
			G
			H
			A
			B
			D
			E

Transmitter setting, end of range	0 °C (or none)
	1. digit defines 100's
	2. digit defines 10's
Examples :	Temperature range 220 °C = 22
	Temperature range 150 °C = 15
	Other
Transmitter setting, start of range	None
	0 °C
	-50 °C
	Other
Transmitter type: As terminal block	Standard
	Galvanically isolated
In hightened lid	Standard
	Galvanically isolated
In Box enclosure	Standard
	Galvanically isolated

¹⁾ Type standard is always 3 wire

Preferred versions

Dimensions

In separate enclosure

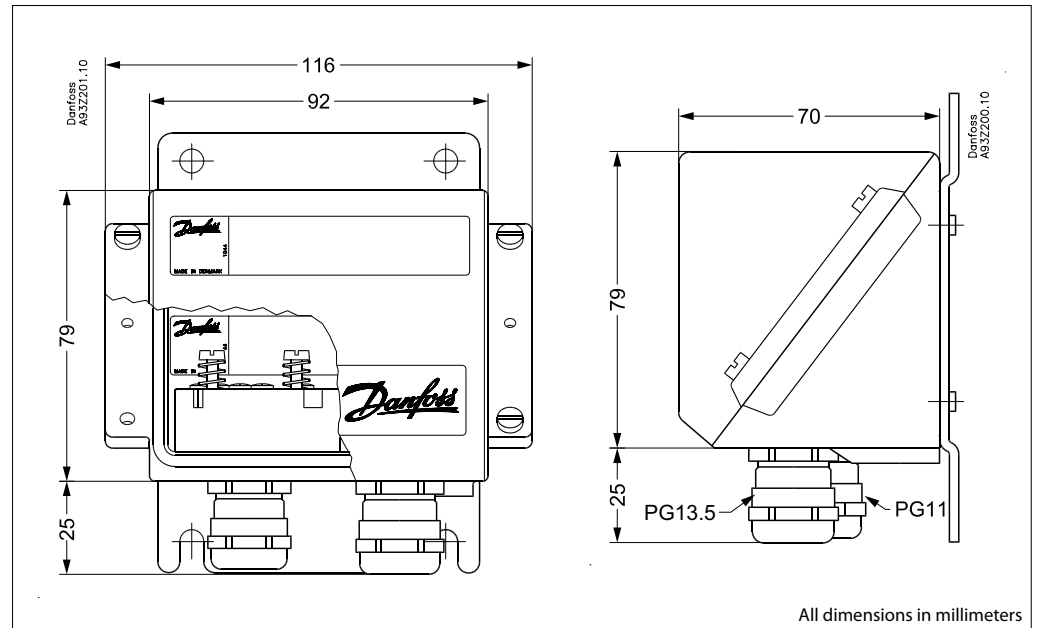

In separate enclosure

